

S2TM Series

- Applications
- Description
- Features

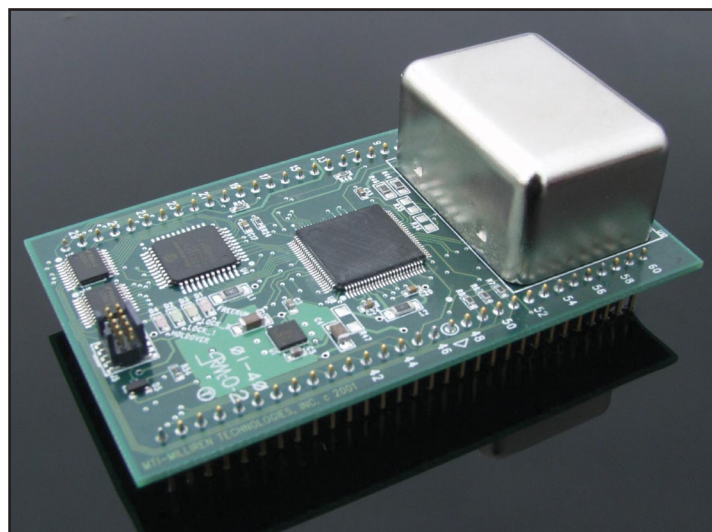

Stratum 2 Timing Module



Applications

- * TDM, PDH, DWDM, SONET, SDH
- * Cellular and WLL base stations
- * Core IP routers and switches
- * Broadband as well as other multi-service access products
- * Cross Connect, ADM and transmission products
- * ATM Wireless Communications

Features

- * Supports free-running, locked, and holdover modes of operation
- * High resolution DSP and unsurpassed direct digital synthesis performance in all modes of operation
- * Pin for pin compatibility reduces design cost
- * Extremely low profile
- * Master-slave redundancy configuration
- * 14 independent user selectable input reference frequencies PLUS fully user programmable in any multiple of 8kHz from 24 kHz to 155.52 MHz (100 MHz TTL)
- * 9 independent user selectable output reference frequencies from 2kHz to 311.04 MHz, plus two sync pulse outputs
- * Available in 5V
- * Manual or automatic hitless switchover
- * Validation of signal prior to selection
- * Phase Build Out (PBO) and phase hit event notification
- * Frequency monitoring of all inputs
- * Programmable wander and jitter tracking and attenuation
- * Upgradeable firmware
- * Development-evaluation kit available

Description

The S2TM series is a complete timing solution for all Stratum 2 synchronous equipment timing source applications (SETS). Our standard model meets the Telcordia GR-1244-CORE, GR-253, as well as the UTI-T G.812 type II specifications.

The S2TM series has an ultra-low profile and measures a mere 3.4" L X 2.0" W X 0.90" H (86.4 X 50.8 X 22.86 mm.) making it the best solution for increasing performance and reliability while maintaining current board design. It comes standard with 14 user programmable input reference frequencies from 8 kHz to 311.04 MHz, allowing any multiple of 8 kHz from 24 kHz to 155.52 MHz (100 MHz TTL) to be supported. Nine user selectable output reference frequencies from 2kHz to 311.04 MHz support 55 industry-standard telecommunications frequencies, as well as two 2 kHz in/out syncs.

The master-slave configuration provides systemwide protection by ensuring redundant synchronization. The Phase Build Out feature allows the module to offset input phasehits through seamless phase transference. Timing signals are further stabilized by attenuating feedback which prevents jitter noise from being passed on to other network elements or clocks.

(over)

S2TM Series

- Block Diagram
- Specifications
- P vs. T Graph
- Contact Us

Description Continued

Holdover stability is $\pm 1 \times 10^{-8}$, and has a programmable pull in range from 0-80 PPM in .08 PPM steps. The S2TM supports free-running, locked, and holdover modes of operation while filtering jitter from the incoming signals. Output signal levels are TTL, AC MOS, LVDS, LVPECL and AMI.

The development and evaluation kit reduces costly functional and quality testing. With nothing more than a standard Windows interface, an engineer can access the advanced features and monitor performance throughout an entire network environment simulation.

Block Diagram

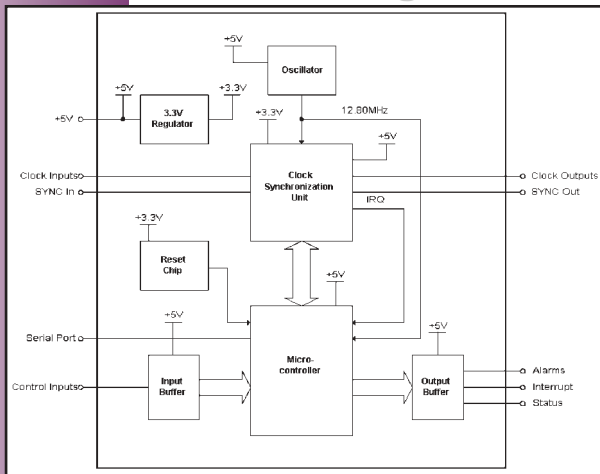

MTI is committed to product innovation as well as enhanced manufacturing techniques, which are redefining the standard in Timing Synchronization Module technology. Each component is precisely tuned to exact requirements which guarantees that every device is an accurate, stable, frequency product of the highest standard, allowing MTI's customers to push their systems to the next level of performance.



Two New Pasture Road
Newburyport, MA 01950
Phone: 978-465-6064
Fax: 978-465-6637

For more information go to
www.mti-milliren.com
or e-mail us at
jdsales@mti-milliren.com

Specifications

Input Signals

Clock Inputs	14 + 2 kHz sync
Input Reference Frequency	2 kHz sync, 8KHz to 155.52 MHz *
Signal Level	TTL, AC MOS, LVDS, LVPECL
Frequency Selection	User-programmable via serial port
Reference Characteristics	Telcordia GR-1244-CORE ITU-T G.812 (type II); G.825

Power

Supply Voltage	5V
----------------	----

Output Signal

Clock Outputs	11 total (9 + (2) 2kHz syncs)
Supported Frequencies	55 total from 2 kHz to 311.04MHz
Signal Level	TTL, AC MOS, LVDS, LVPECL, AMI
Frequency Selection	User-programmable via serial port
Reference Characteristics	Telcordia GR-1244-CORE ITU-T G.812 (type II); G.825

Signal Quality Performance

Jitter and phase tolerance	Telcordia: GR-1244-CORE-4.2 & 4.3
Phase transient tolerance	GR-1244-CORE-4.4
Wander generation	GR-1244-CORE-5.3
Wander tolerance	GR-1244-CORE-4.3
Wander transfer	GR-1244-CORE-5.4
MTIE	GR-1244-CORE-5.4
TDEV	GR-1244-CORE-5.4

Monitoring

Alarms	3 alarms, 8 status accessible via serial port
--------	---

DPLL Performance

Free run accuracy	$\pm 1.6 \times 10^{-8}$
Holdover stability	$\pm 1 \times 10^{-10}$ / day
Pull in range	± 9.2 PPM **
Lock accuracy	$\pm 1 \times 10^{-11}$

Physical Characteristics

Width	2.0"(50.8 mm)
Length	3.4"(86.4 mm)
Height	0.90"(22.86 mm)

* any multiple of 8 kHz from 24 kHz to 155.52 MHz (100 MHz TTL) can be supported

** default setting, any progression from 0-80 PPM in .08 PPM steps is achievable

Performance vs. Temp Graph

